

Designer Circle Bag

and matching 3x3 notecards

Supplies:

- 1 sheet of Designer Series Paper
- 2-3 sheets of 12"x12" Cardstock
(to coordinate with the designer series paper)
- 6" diameter bowl or pot lid
- 12" Paper Cutter and Scissors
- Sticky Strip or Glue Stick
- Large Oval Punch
- Stamps & Stamp Pads
- Extra cardstock for layering
- Mini Square Envelopes
- Paper lunch bag (approx 4" wide)
- Ribbon (for embellishing cards if desired)



Artwork © Stampin' Up!® 1990-2007

Directions:

Cut 5-1/2" off of one edge of the designer series paper so you have a 5-1/2" x 12" strip. Set the rest aside for now. Glue this 5-1/2" x 12" piece to the same size piece of coordinating cardstock. Cut in half to make two 5-1/2" x 6" pieces. Trace a semicircle onto one of the pieces using a bowl or pot lid leaving the bottom edge straight. Lay the piece with the pattern traced on it on top of the other and cut both pieces at the same time. Use the oval punch to create a handle on both pieces. Cut the paper bag so it's about 3-1/2" tall. Adhere the circle shapes onto each side of the lunch bag using glue stick or sticky strip. Your bag is now done!

Using the diagram below (or one from the next page), cut the remaining piece of designer paper. If you use this pattern, you will have enough pieces to make 14 card fronts for your 3x3 cards. The long narrow strip is to embellish the outside of the bag. (You may want to layer this onto a piece of coordinating cardstock first for more contrast). Glue this piece to the front side of the circle bag and cut off excess.

Cut your remaining coordinating 12" x 12" cardstock into 3" x 6" pieces - these will be your 3x3 cards when you fold them in half. (Note: you can get 8 cards from 1 sheet of 12x12 cardstock if you cut it in half first and then cut 3" strips from each half). Use the pieces of designer series paper that you have cut using the diagram below (or from one of the other guides on the next page) to embellish the cards as desired. You may also want to add some additional stamped images at this time.

When you're done, place the cards as well as envelopes into the bag and you have made a very cute and unique gift!

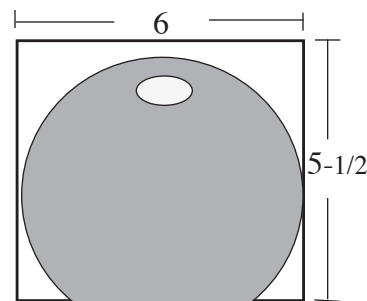
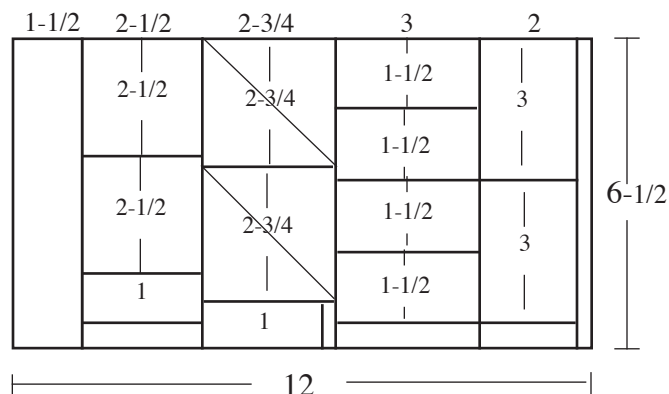

Chiaki Haverstick

Stampin' Up! Demonstrator

(714) 550-9342

e-mail: chiaki@stampingpro.com

visit my websites at:

www.stampingpro.com and www.chiaki.stampinup.net

Designer Circle Bag

Additional cutting guides

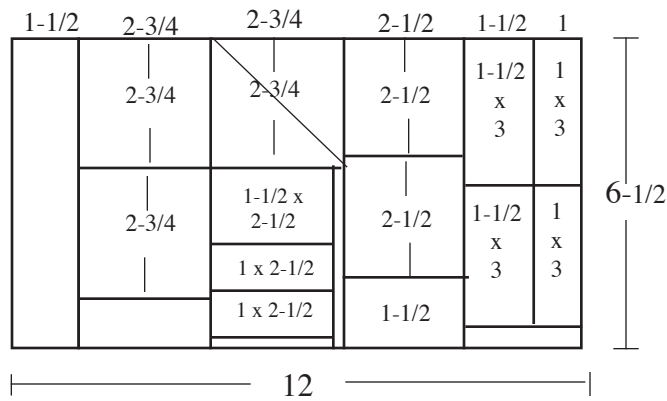
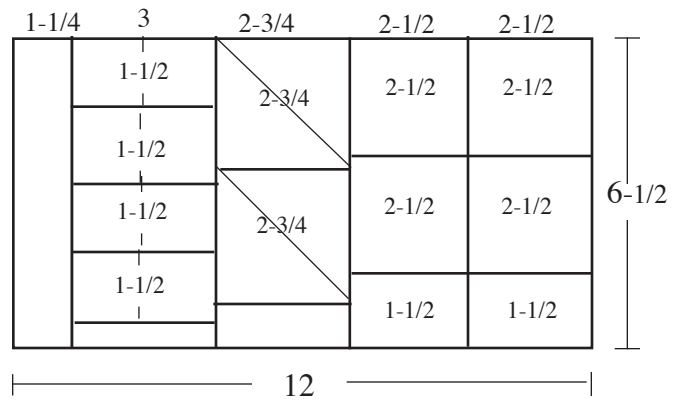
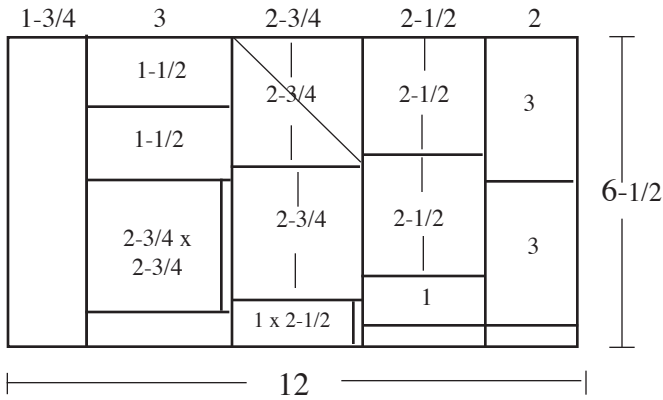

Cutting Guides for Vertically Striped Paper

